

EPSON

PF-10

OPERATING MANUAL

FEDERAL COMMUNICATIONS COMMISSION
RADIO FREQUENCY INTERFERENCE
STATEMENT

"This equipment generates and uses radio frequency energy and if not installed and used properly, that is, in strict accordance with the manufacturer's instructions, may cause interference to radio and television reception. It has been type tested and found to comply with the limits for a Class B computing device in accordance with the specifications in Subpart J of Part 15 of FCC Rules, which are designed to provide reasonable protection against such interference in a residential installation. However, there is no guarantee that interference will not occur in a particular installation. If this equipment does cause interference to radio or television reception, which can be determined by turning the equipment off and on, the user is encouraged to try to correct the interference by one or more of the following measures:

- reorient the receiving antenna
- relocate the computer with respect to the receiver
- move the computer away from the receiver
- Plug the computer into a different outlet so that computer and receiver are on different branch circuits.

If necessary, the user should consult the dealer or an experienced radio/television technician for additional suggestions.

The user may find the following booklet prepared by the Federal Communications Commission helpful: "How to Identify and Resolve Radio-TV Interference Problems."

This booklet is available from the US Government Printing Office, Washington, D.C., 20402, Stock No. 004-000-00345-4.

This statement will be applied only for the printers marketed in the U.S.A.

The connection of a non-shielded printer interface cable to this floppy disk unit will invalidate the FCC Certification of this device and may cause interference levels which exceed the limits established by the FCC for this equipment.

FOREWORD

Your PF-10 is a compact, yet powerful battery-operated portable floppy disk unit designed as an external memory unit for portable computers. Please read this manual carefully before operating the unit.

CAUTION

Service voltages vary depending on countries. When using your PF-10 with an AC adapter, be sure to use one that is suitable for the voltage in your country.

TABLE OF CONTENTS

Chapter 1. BEFORE OPERATION	
1.1 Unpacking.....	1
1.2 Names of Parts	1
1.3 Built-in Battery.....	1
1.3.1 Battery Exchange.....	1
1.3.2 Recharging the Main and Sub Batteries	1
1.3.3 Battery Specifications	1
1.3.4 AC adapter	1
1.4 Precautions to Observe When Using The PF-10	1
Chapter 2. CONNECTION WITH COMPUTER	
2.1 Connection with PX-8.....	2
2.2 Drive Extension of the PF-10.....	2
2.3 Software Description	2
2.3.1 Physical Disk Format	2
2.3.2 Logical Disk Format.....	2
2.3.3 File Directory Structure	2
Chapter 3. OPERATION	
3.1 Setting Disks in the Disk Drive.....	3
3.2 Removing Disks from the Disk Drive	3
Chapter 4. FLEXIBLE DISK	
4.1 Configuration of Flexible Disk	4
4.2 Use of the Write Protect Switch.....	4
4.3 Care and Handling of Flexible Disks.....	4
Chapter 5. SYSTEM CONFIGURATION	
5.1 Outline of the PF-10	5
5.2 Interface.....	5
Chapter 6. SPECIFICATIONS	6

Trademark Acknowledgments

CP/M® is a registered trademark of Digital Research™.

BASIC (Copyright 1977 – 1983 by Microsoft and Epson) is upward compatible with the BASIC-80 specifications of Microsoft, Inc.

NOTICE

- All rights reserved. Reproduction of any part of this manual in any form whatsoever without EPSON's express written permission is forbidden.
- The contents of this manual are subject to change without notice.
- All efforts have been made to ensure the accuracy of the contents of this manual. However, should any errors be detected, EPSON would greatly appreciate being informed of them.
- The above notwithstanding, EPSON can assume no responsibility for any errors in this manual or their consequences.

© Copyright 1984 by EPSON CORPORATION
Nagano, Japan

Chapter 1. BEFORE OPERATION

1.1 Unpacking

Open the carton box and confirm that all items shown in Fig. 1-1 are contained in the box. If any item is missing or damaged, please contact the shop where you purchased your PF-10.

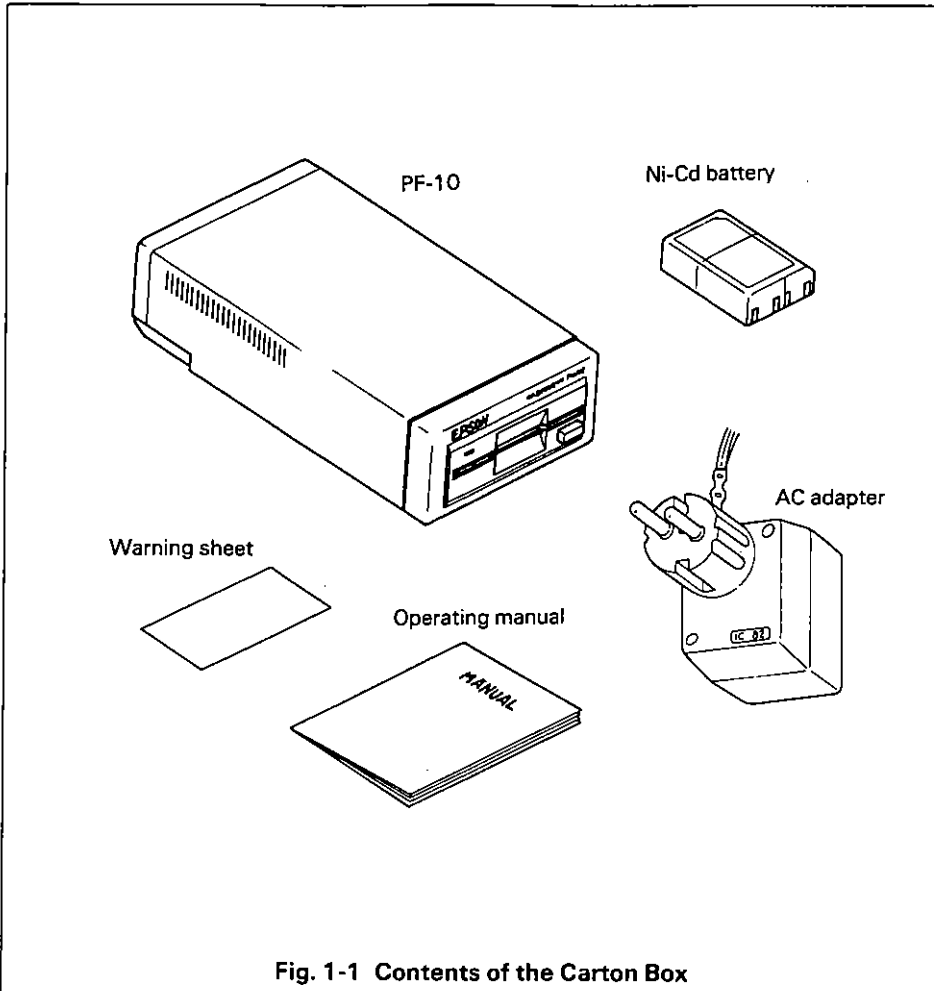
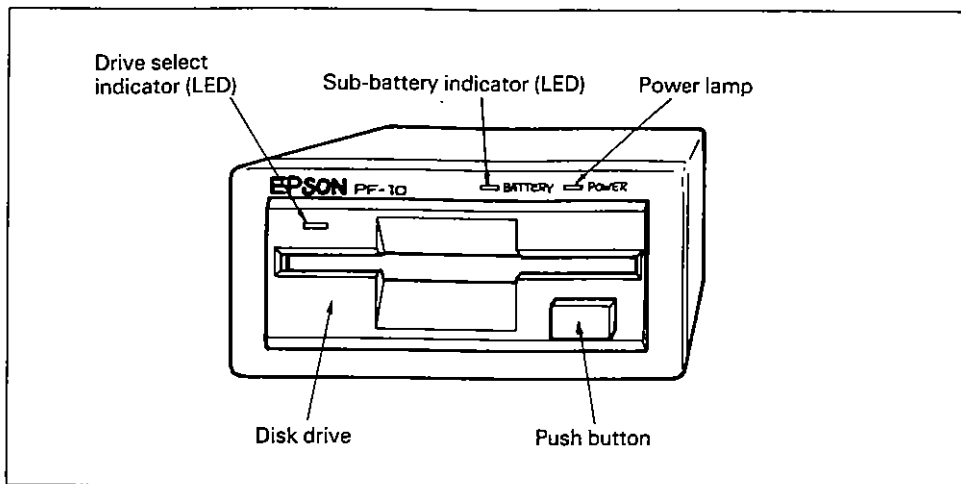

Fig. 1-1 Contents of the Carton Box

Note: Keep the carton and packing materials. You may need them in the future, if the PF-10 must be transported again.

1.2 Names of Parts

«Front Panel»



- ① **Push button**
This is used to remove the floppy disk from the disk drive.
When a floppy disk is inserted in the disk drive and this button is depressed, the disk will come out of the drive by an inch or so, allowing it to be easily removed.
- ② **Drive select indicator (red LED)**
This lamp lights up when the drive is operating. Never take out a disk from the disk drive while this lamp is alight. The disk may be damaged or the stored data may be destroyed.
- ③ **Disk drive**
This is a 3.5-inch compact-size flexible disk drive.
The drive uses double sided, double density disks, and provides for 40 tracks per side, which is compatible with the 5.25-inch standard disk tracks. Since it consumes very little power, this disk drive can be battery driven.
- ④ **Sub-battery indicator (red LED)**
If the main battery voltage falls below the specified value, the sub-battery is automatically activated, turning on the sub-battery indicator. When this lamp lights up, stop using the PF-10 as soon as possible, and either recharge the main battery pack or use new dry batteries.
- ⑤ **Power lamp (red LED)**
This lamp lights up when the power is turned on.

«Rear Panel»

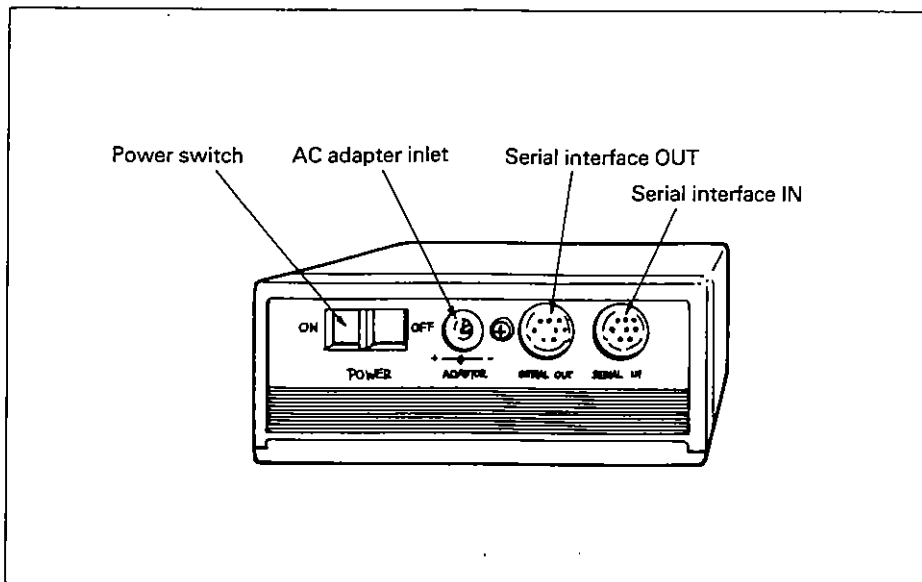

⑥ Serial interface IN connector

This is the connector for signals to control the floppy disk drive. The drive is connected to a host computer through various types of cables. The transmission rate is 38.4 k bits/sec.

⑦ Serial interface OUT connector

This connector is used for extending the floppy disk drives. Another drive can be added to the PF-10, which are designated as drive D and F.

⑧ AC adapter inlet

An AC adapter for battery recharging is connected to this inlet.

⑨ Power switch

This switch turns on and off the power.

«Rear Side»

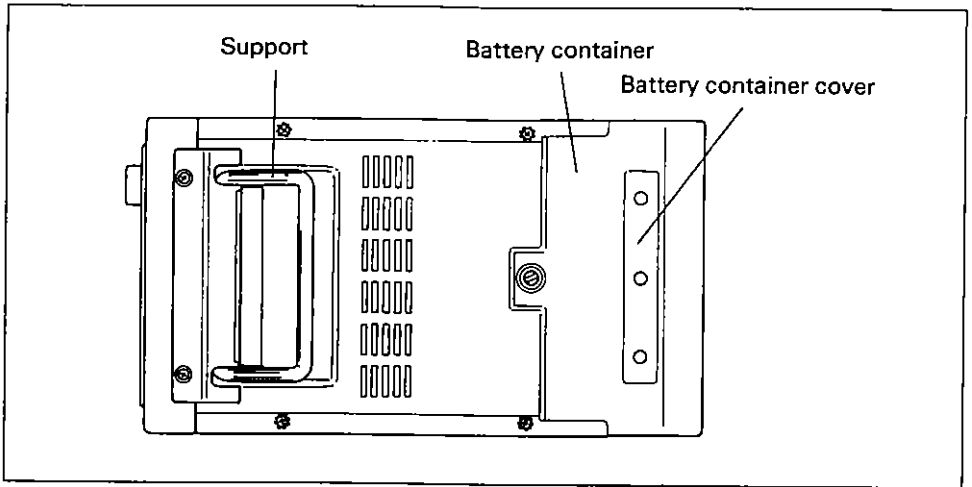

⑩ Support

This is used to position the angle of the PF-10 for ease of use.

⑪ Battery container

The supplied Ni-Cd battery pack or dry batteries (alkaline LR14, SUM-2 x 4) can be used.

Note: When using dry batteries, the PF-10 may not operate if the sub-battery is not sufficiently charged.

⑫ Battery container cover

Open this cover when exchanging batteries.

1.3 Built-in Battery

The PF-10 can be used with either the supplied Ni-Cd battery pack or commercially available dry batteries.

When the battery power has run down and the voltage has dropped below the specified value, the sub-battery is automatically activated and the sub-battery indicator lights up.

Stop using the PF-10 as soon as possible when this condition arises and either charge the rechargeable battery pack or exchange the dry batteries.

Caution

If you continue to use the PF-10 when the sub-battery lamp is lit, the PF will stop operating and the sub-battery lamp will flash. This means that sub-battery must be recharged. Care should be taken to avoid this condition for not only may the data in the PF-10's buffer be lost but the data on the d may also be destroyed.

(The sub-battery is incorporated inside the PF-10.)

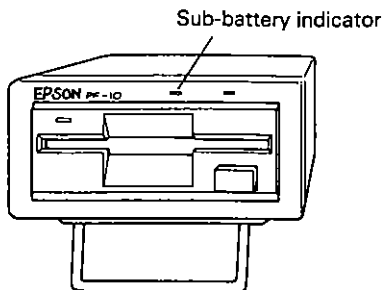

1.3.1 Battery Exchange

To change the battery carry out the following procedure:

Steps

- (1) Set the power switch to the OFF position.
- (2) If the AC adapter is connected remove it.
- (3) Turn the PF-10 upside down. Unscrew the retaining screw of the battery container cover.
- (4) Remove the battery container's cover by sliding it in the direction of the arrow.

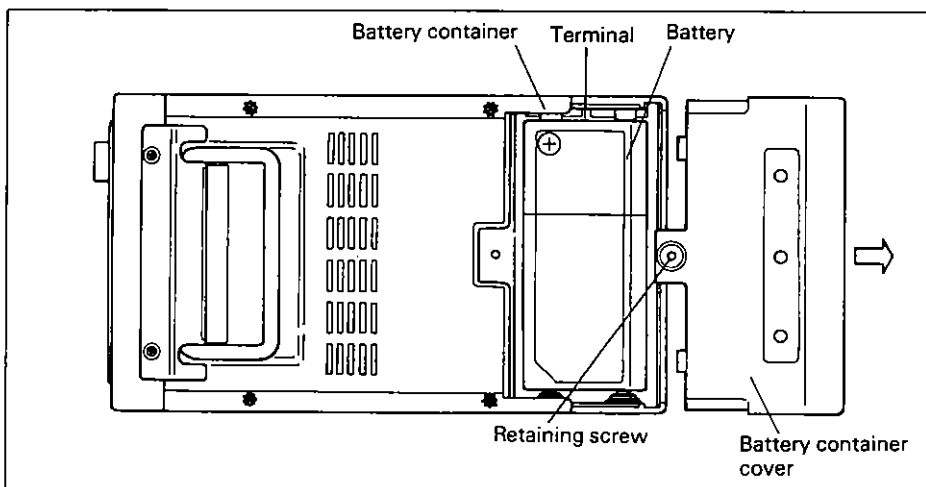

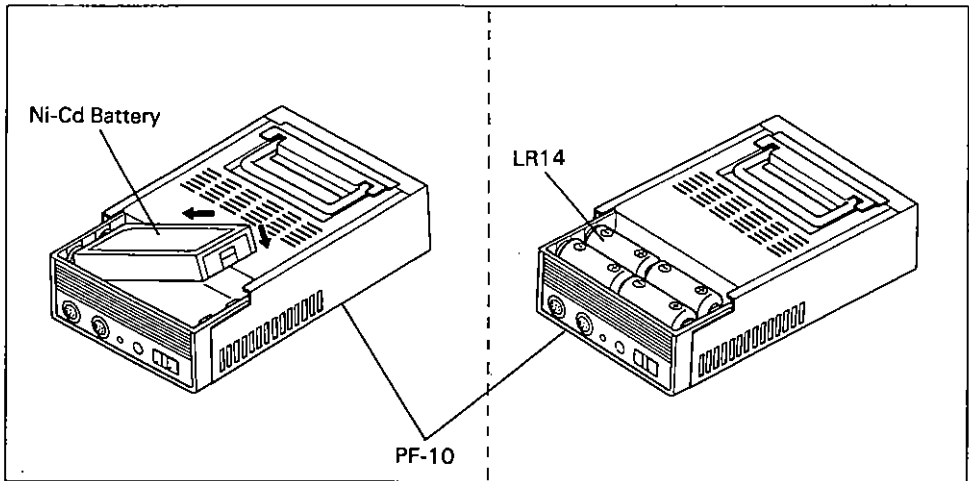

- (5) Install the supplied Ni-Cd battery pack or 4 dry batteries (alkaline LR14, SUM-2) into the battery container with correct polarity.
- (6) Reinstall the battery container cover.

1.3.2 Recharging the Main and Sub Batteries

Use the supplied AC adapter, or an optional AC adapter HOODA. Turn off the PF-10's power switch when recharging the batteries. The batteries will be fully charged by recharging them for approximately 8 hours.

Caution

To avoid overcharging the batteries, do not leave the AC adapter connected to the unit for more than 24 hours.

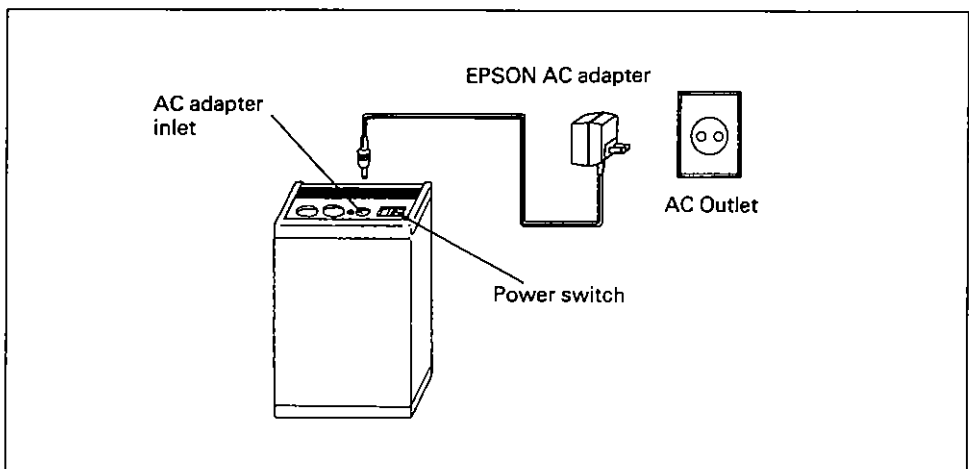

1.3.3 Battery Specifications

(1) Battery voltages

- | | |
|---------------------------|-------------|
| (a) During operation | 4.0 to 6.0V |
| (b) Low voltage detection | Below 4.0V |

(2) Battery capacity

1000 mAH when fully charged.

(The figure indicates the value until the sub-battery indicator lights up.)

(3) Battery life

The battery life varies depending on how the battery is used, e.g., the ambient temperatures, the recharging method (how long and when recharging were done), etc. The standard battery life is considered to be 3 years. Replace the battery as soon as possible after this period.

If the discharge time has been extremely shortened even after the battery is fully charged, the battery should be exchanged.

1.3.4 AC Adapter

- Do not operate the unit using the supplied AC adapter (H00AA) without connecting the battery. When the power switch is turned on, recharging of the battery cannot be guaranteed.
- When using the optional AC adapter (H00DA), the unit can be operated with the adapter only; recharging the battery while using the unit is possible in this case.
- Be sure to use only EPSON AC adapters. Use of other AC adapters may cause the battery and the internal circuits to be damaged.
- Make sure that the AC adapter you are going to use corresponds with the service voltage.
- Be sure to disconnect the AC adapter from the unit when you are not using the adapter.

1.4 Precautions to Observe When Using the PF-10

Situating the Unit

This unit is a precision machine. Please pay attention to the following points:

- ① Do not use or store it at a position exposed to the sun or other heater.
- ② Do not store or use it at a place exposed to extremely high or low temperatures, or where the temperature changes rapidly.
- ③ Do not store or use it in a place exposed to extreme humidity, oil mist or dust containing iron particles.
- ④ This disk drive unit incorporates precision components. Do not apply any shock to it or use it in a place exposed to vibrations.
- ⑤ The unit may malfunction when operated near a device that creates strong magnetic fields. Be sure to use it at a distance from such devices.
- ⑥ Be sure to use the PF-10 only in the manner illustrated below:

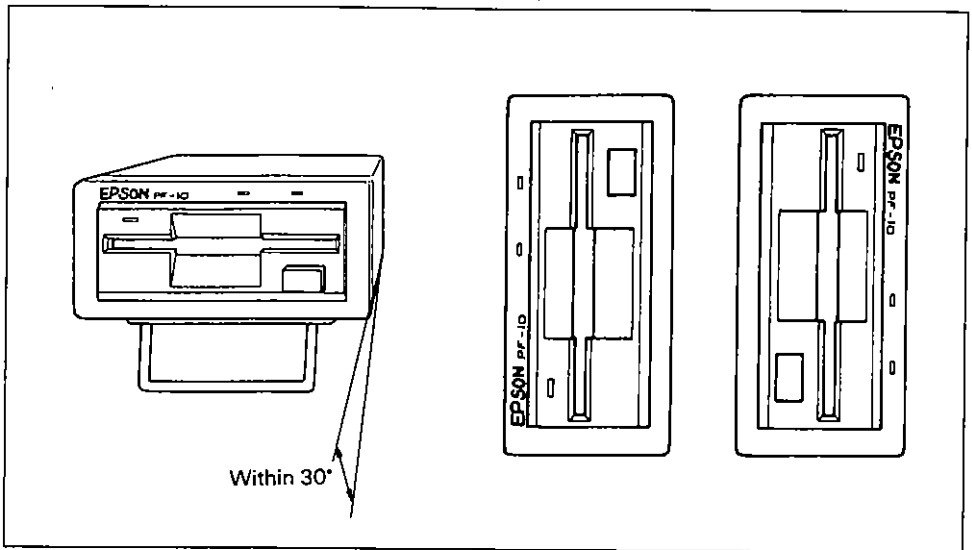

- ⑦ When the unit is not to be used for a long period, disconnect the batteries from the battery container.
- ⑧ Remove the protective sheet for shipping from the drive unit. The unit may malfunction when used with the sheet inserted in the drive.
- ⑨ When taking the unit to another location, insert the protective sheet into the drive. Never ship the unit with a floppy disk inserted in the drive, or the head will be damaged.

Chapter 2. CONNECTION WITH COMPUTER

2.1 Connection with PX-8

«Use cable set # 726 for the connection.»

Steps

- (1) Turn off the power to the PF-10 and the PX-8.
- (2) Use cable set # 726 to connect the serial interface connector of the PX and the serial interface IN connector of the PF-10.

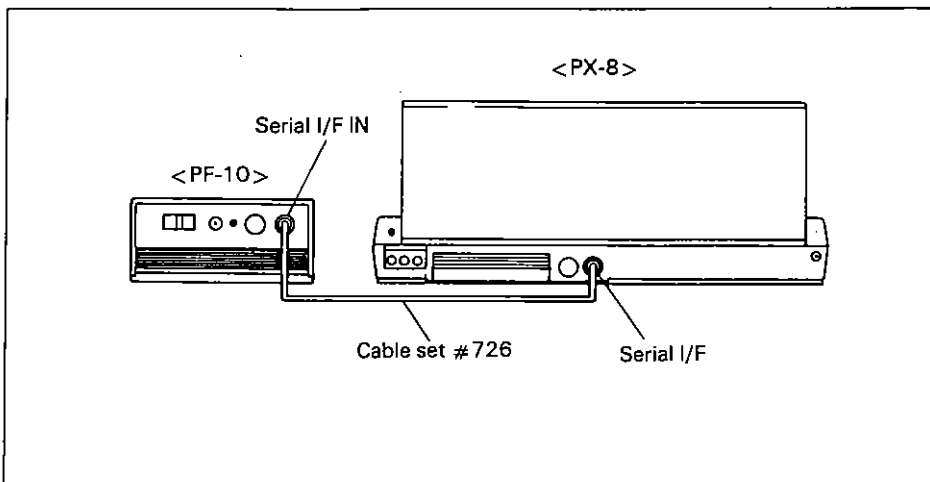

- The PF-10 is designated as drive D. (When the drive extension is execute units are respectively designated as drive D and F.)
- The transmission rate is 38.4 k bits/sec.

2.2 Drive Extension of the PF-10

Another drive can be added to the PF-10 by using the daisy chain connections (Serial Interface OUT). For data signalling with the host computer, 2 transmission rates can be selected, 38.4 k bits/sec.

Steps

- (1) Set the PF-10's power switch to the OFF position.
- (2) Disconnect the battery from the PF-10.
- (3) To extend drives:
 - Set pin 3 on the DIP switch to the OFF position.

To change the transmission rate:

Set pin 4 on the DIP switch to the ON position.

The transmission rate is normally set to 38.4 k bits/sec (by setting pin 4 on the DIP switch to the ON position).

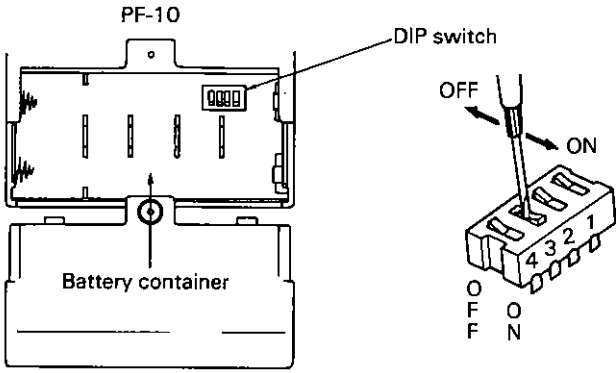

DIP switch setting

Pin No.	Signal Name	Function			
1	Not used	ON	—		
2	Not used	ON	—		
3	Drive setting	ON	Drive D specified (Setting at the time of shipment)	OFF	Drive F specified
4	Transmission rate	ON	38.4 k bits/sec (Setting at the time of shipment)	OFF	—

(4) Reinstall the battery, and then replace the battery container cover.

Connections for Extending Drives:

Use cable # 726 to execute the daisy chain connections (Serial I/F OUT).

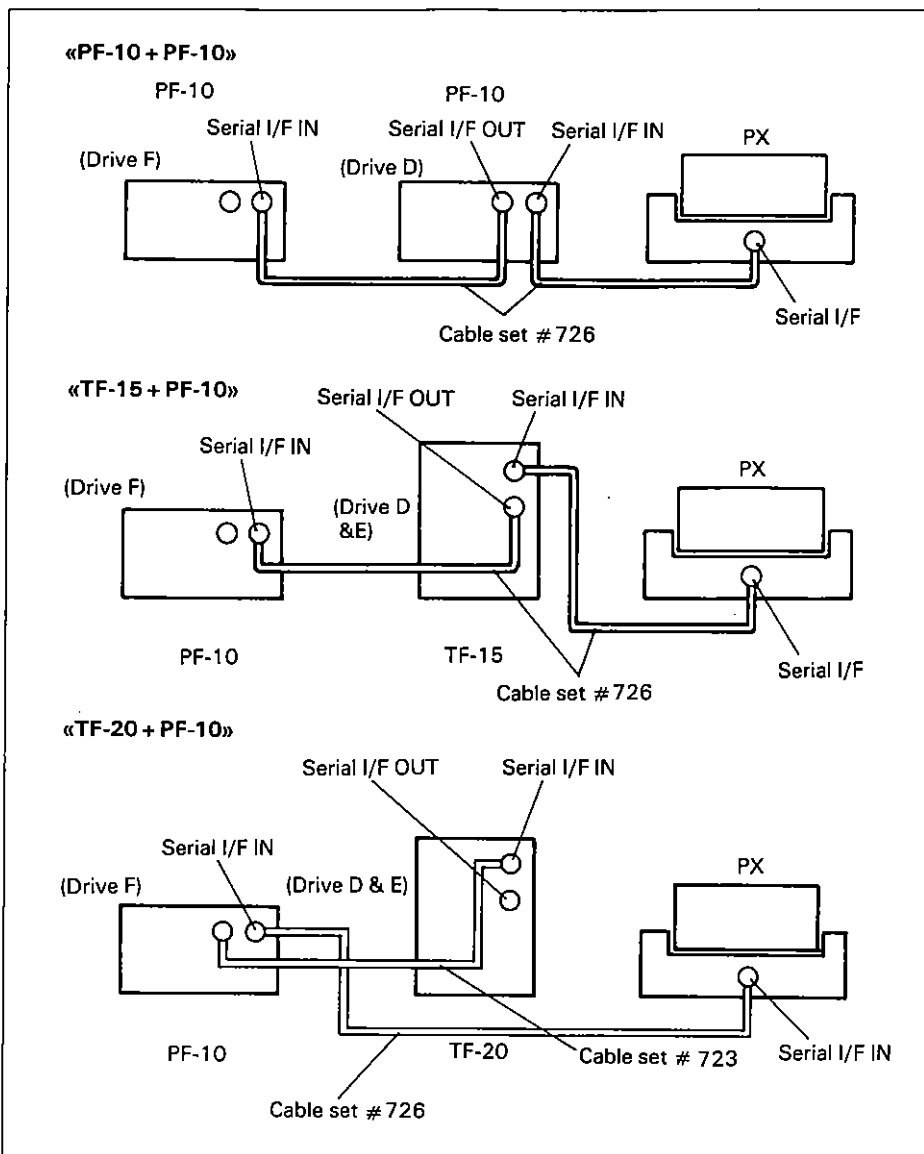

2.3 Software Description

The PF-10 incorporates a ROM which accommodates the DOS (disk operating system) for the PX-8. This means that no special system software is required when using a formatted 3.5-inch flexible disk manufactured by EPSON. Access (reading and writing) from the PX-8 to the PF-10 is possible by designating the drive name, file name, and extension. The first drive is designated as drive D; the second, when connected through daisy chains, is designated as drive F.

To save a program, for example, while using EPSON BASIC, write as follows:

```
SAVE "<Drive name>: <File name.>·<Extension>".
```

Example

To save a program written in BASIC under the file name "TEST" and extension "BAS" on a disk inserted in the first drive, write as follows:

```
SAVE "D: TEST·BAS"
```

Many disk utilities and various types of application software are available for enhancement of the PX-8's functions.

2.3.1 Physical Disk Format

The mini floppy disks used for the PF-10 are double-sided which means that data may be stored on both sides of the disks.

The recording surface of the disk is divided into 40 concentric bands, called tracks.

These are referred to, from the outermost to the innermost, as tracks 0 to 39.

Furthermore, the length of each track is divided into 9 segments, called sectors.

Each sector can contain up to 512 bytes of data. These tracks and sectors are the basic physical unit used for data storage, and numbered as shown below.

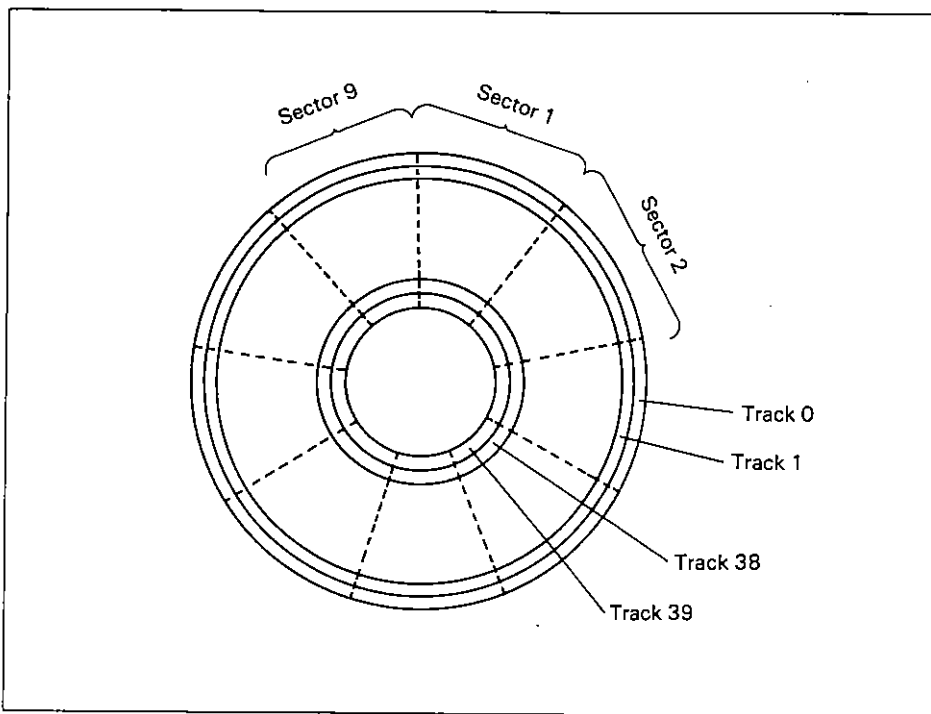

2.3.2 Logical Disk Format

As long as you use the disk for daily operation, you do not need to consider physical tracks and sectors because CP/M finds them for you once you specify the file name.

However if you want to use more advanced functions, you need to know the logical disk format.

In logical disk format, you have 40 logical tracks and 64 sectors.

The BDOS always transfers data in units of 128 bytes, which is the basic record size of the file handling, called the "data block size".

Since BDOS allocates disk space to files according to this data block size, the logical disk format is totally different from the physical one described above.

The following illustrates logical disk format for PX-8 CP/M.

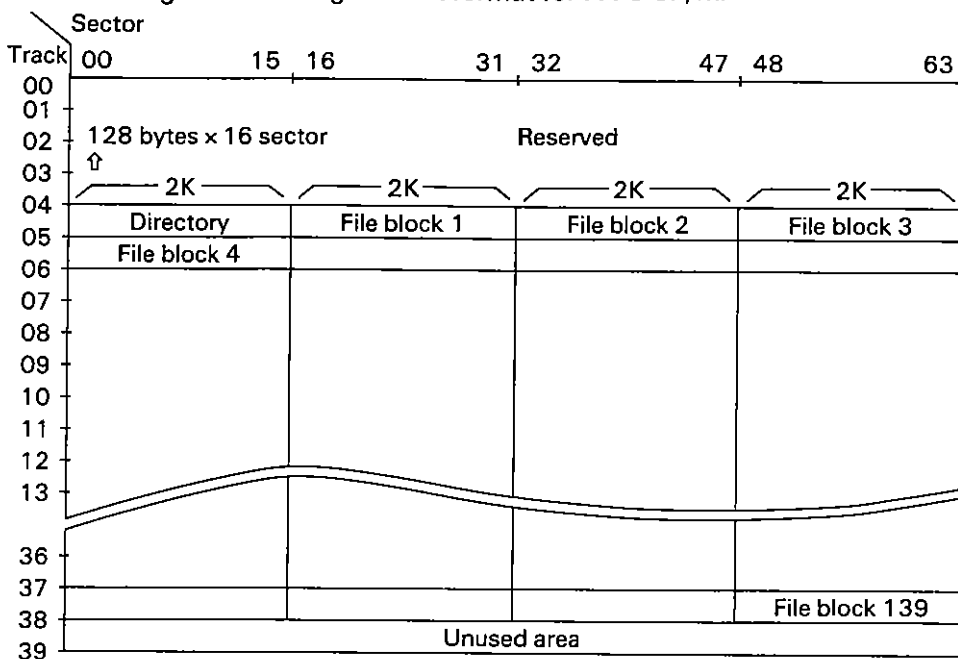

The file directory of PF-10 utilities disk uses sectors 0 to 15 of track 4. This directory contains the names, locations, and attributes of all files on the disk.

Disk locations from sector 16 of track 4 through sector 63 of track 38 are used as user data area. This area is divided into 139 2k-byte blocks, and BDOS manages the file based on the numbers of these blocks.

2.3.3 File Directory Structure

Up to 64 files can be cataloged in the file directory, which is divided into 6 32-byte blocks.

Each directory block manages up to 32k bytes of a file.

When the size of a file exceeds 32k bytes, additional directory blocks must be used together with the same cataloged file name. When the entire user area of a disk is used for a single file, 9 directory blocks are required to manage the file.

The structure of each directory block is shown below.

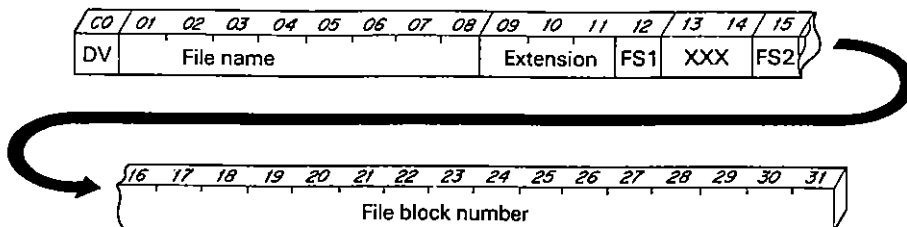

byte(s)		Contents
00	DV	Indicates whether or not the directory block is valid. 00H: Valid E5H: Invalid
01 to 08		File name
09 to 11		Extension (File type) When the MSB of the first byte of the file type is referred to as $t1$ and MSB of the second byte as $t2$, $t1 = 0$ R/W file = 1 R/O file $t2 = 0$ DIR file = 1 System file
12	FS1	Indicates the file size in 16k-byte (128-sector) units. A number from 0 to 17.
13 to 14		Not used
15	FS2	Indicates the file size in sector units. A number from 0 to 128.
16 to 31		Contains block numbers in which the file is written.

Example 1:

00 50 49 50 20 20 20 20 20 43 4F 4D 00 00 00 3A
36 37 38 39 00 00 00 00 00 00 00 00 00 00 00 00

The file name is
PIP.COM and its size
is 58 sectors.

Example 2:

E5 54 45 53 54 20 20 20 20 41 53 4D 00 00 00 80
01 02 03 04 05 06 07 08 00 00 00 00 00 00 00 00

The indicated file
(TEST.ASM, which
has a length of 128
sectors) has been
erased.

Example 3:

00 45 50 53 4F 4E 20 20 20 44 41 54 01 00 00 80
01 02 03 04 05 06 07 08 09 0A 0B 0C 0D 0E 0F 10

The file name is
EPSON.DAT and the
size of the file is
2224 sectors.
(128 × 17 + 48)

00 45 50 53 4F 4E 20 20 20 44 41 54 11 00 00 30
81 82 83 84 85 86 87 88 89 8A 8B 00 00 00 00 00

Chapter 3. OPERATION

3.1 Setting Disks in the Disk Drive

Step 1

Take out the protective sheet for shipping. To do this, press the push button on the drive, and the sheet will project from the drive by about an inch for easy removal. (Please keep the sheet for possible reshipment. Shipping the disk unit without the sheet inserted in the drive may damage the head, as the head cannot stay at a stable position.)

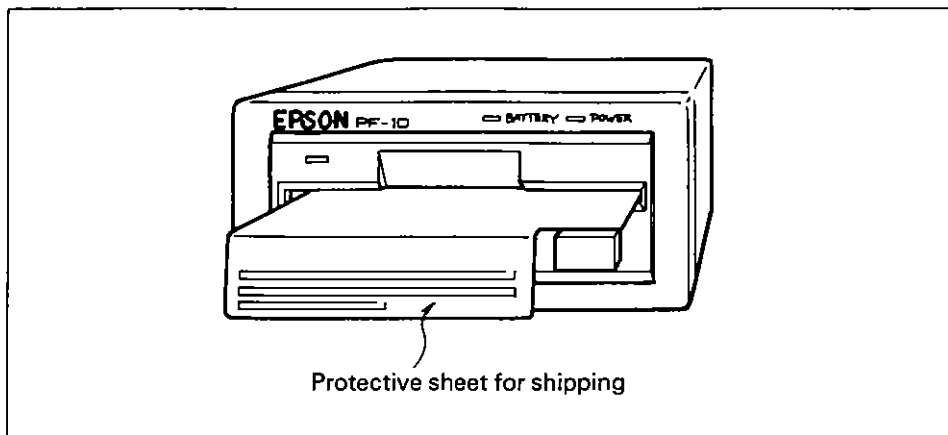

Step 2

Insert a floppy disk with the hub part facing downward into the drive.

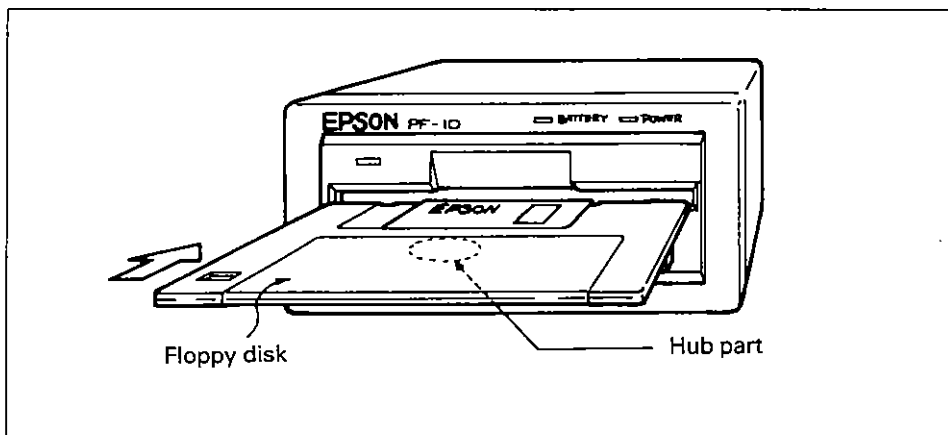

Step 3

As the floppy disk is inserted still further, a clicking sound will be heard. The disk is set in position in the drive.

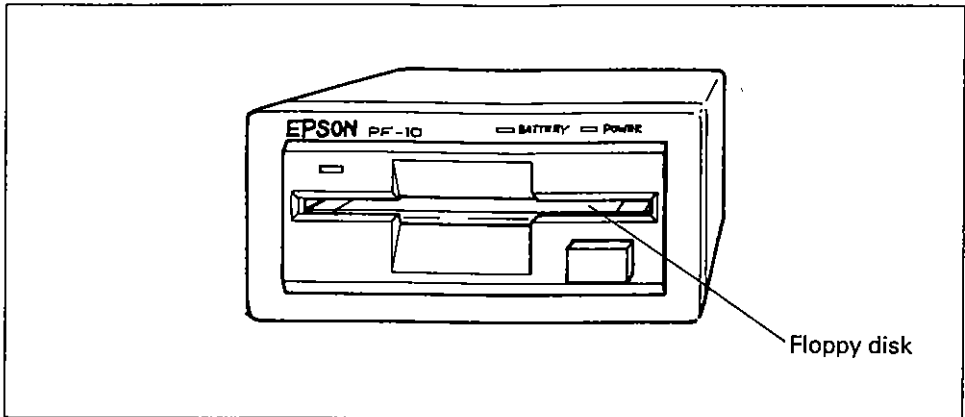

3.2 Removing Disks from the Disk Drive

When the drive select indicator is alight, the floppy disk in the drive must not be taken out, or else the disk will be damaged and the stored information lost.

Step 1

Depress the push button, and the disk will come out from the drive by one inch or so.

Step 2

Take out the disk, straight forward without bending it.

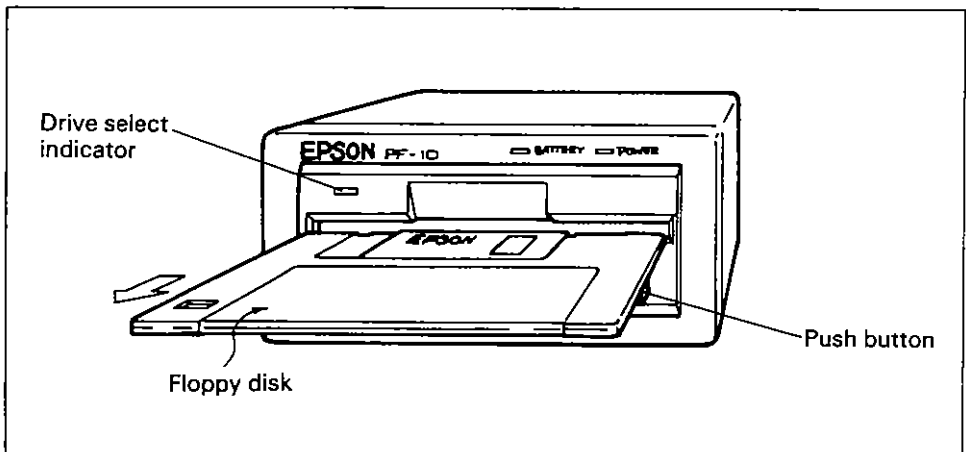

Chapter 4. FLEXIBLE DISK

4.1 Configuration of Flexible Disk

The micro-floppy disk for the PF-10 has the same memory capacity as that conventional double sided, double density mini floppy disks. Unlike the conventional type, however, the PF-10's flexible disk has a different configuration: the flexible disk is contained in a hard plastic case provided with a head window which is closed when the disk is not in use. As a result, the danger of touching the magnetic surface of the disk with hands has been minimized. The EPSON 3.5-inch flexible (floppy) disks are double sided, double density disks, already formatted in the format of tracks 80, 9 sectors/track, and 51 bytes/record.

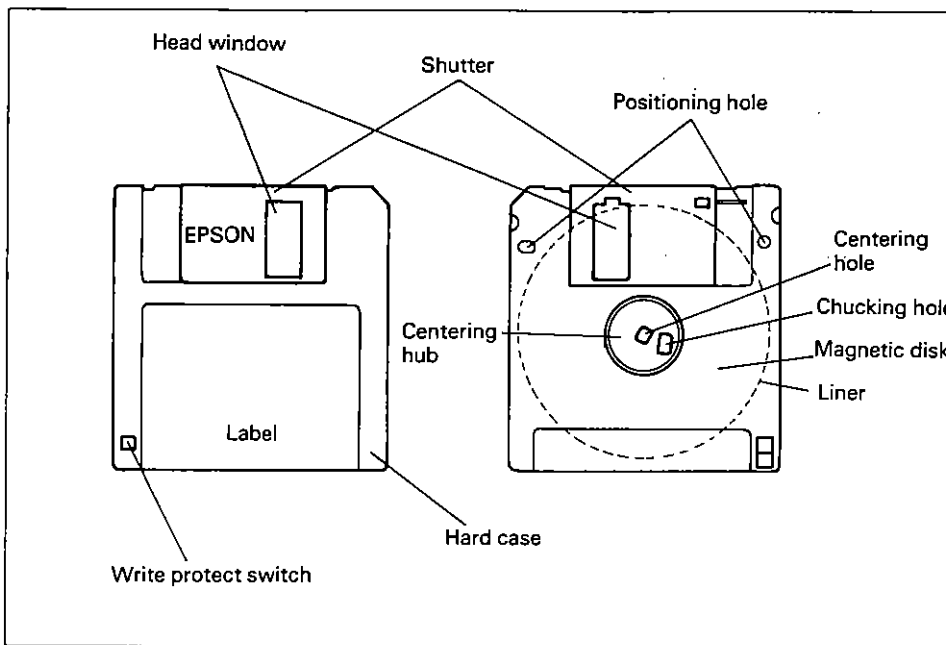

- **Head window:**

The magnetic head of the drive unit and the disk comes into contact at this part. The window is closed with the shutter for protection when the disk is not in use.

- **Shutter:**

The metallic shutter automatically opens when the disk is inserted into the drive.

- **Hub:**
High reliability of the plastic hub allows precise tracking positions to be maintained.
- **Write protect switch:**
When the tab on the write protect switch is moved with a pointed object such as a ball pointed pen so that the write protect hole is completely opened, the disk will be write protected. Use this feature for protecting valuable data programs so that they can not be over written or erased.
- **Magnetic disk:**
The diameter of the disk is only 72 mm. However, use of an epitaxial magnetic material has provided the disk with a same memory capacity as that of 5-inch type floppy disks.
- **Hard case:**
The case is manufactured a tolerance of ± 1 micron to ensure further reliability in positioning the disk in the drive.

4.2 Use of the Write Protect Switch

The write protect switch mechanically disables writing on the micro-floppy disk. It is used to protect the information stored in the disk.

● How to write protect the disk

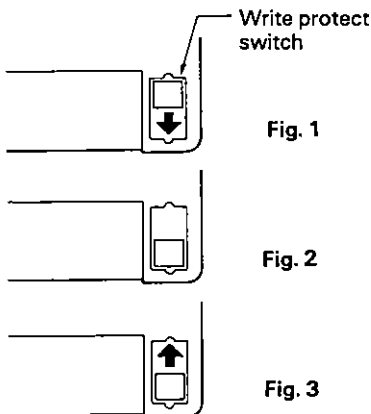

Slide the red write protect switch in the direction of the arrow in Fig. 1 until it clicks. (See Fig. 2)

The disk is now write protected; no writing on the disk is possible. To cancel the write protection on the disk, slide the write protect switch in the direction of the arrow in Fig. 3 until it clicks.

4.3 Care and Handling of Flexible Disks

- ① No solvents such as thinner, alcohol, or freon should be used to clean the disks.



- ② Do not allow a magnet to get near to the disk. If you do or if it is exposed to a magnetic field the data stored on the disk may be erased or corrupted.

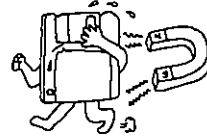

- ③ Do not place any object on the disk. Placing a heavy object on the disk may deform the case, disabling it for further use.

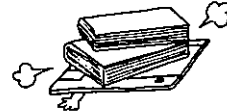

- ④ Do not open the shutter. This may result in attachment of foreign objects to the magnetic surface, causing errors to occur.

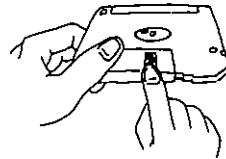

- ⑤ Affix a label at the correct position. When placing a new label, do not put it on top of another label.

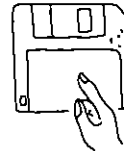

- ⑥ Insert the disks gently into the drive. Careless insertion and removal of the disk will damage its case, and the disk may not be correctly set in position.



- ⑦ Do not use a disk which has been contaminated by liquids such as soft drinks or coffee, or on which dust such as rubber eraser particles or metal powder is attached.

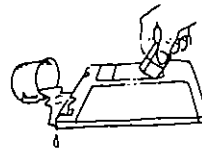

- ⑧ Do not take a floppy disk to piece.

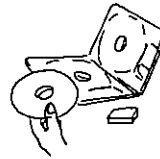

- ⑨ Do not use or store the disk at a place exposed to high temperatures, humidity, sunlight, or dust.

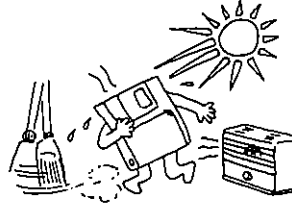

- ⑩ The environment for operation is as follows:

Temperatures: 10 to 50°C

Humidity: 20 to 80% RH. (provided that the wet tube temperature is below 29°C)

Do not allow the unit to be exposed to a sudden change of temperatures. (Do not allow the temperature change to exceed 20°C per hour.)

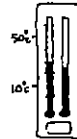

- ⑪ The environment for storage is as follows:

Temperatures: 4 to 53°C

Humidity: 8 to 80% RH

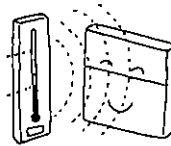

- ⑫ The environment for shipping is as follows:

Temperatures: -50 to +53°C

Humidity: 8 to 90% RH.

Be sure to put the unit in the carton box when shipping it to other locations.

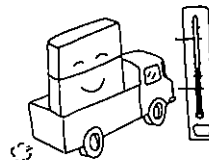

Chapter 5. SYSTEM CONFIGURATION

5.1 Outline of the PF-10

The PF-10 consists of the CPU, ROM (8 k), RAM (2 k), FDC, READ AMP, VFO and 3.5-inch compact flexible disk drive; it is a portable floppy disk drive unit provided with intelligent functions.

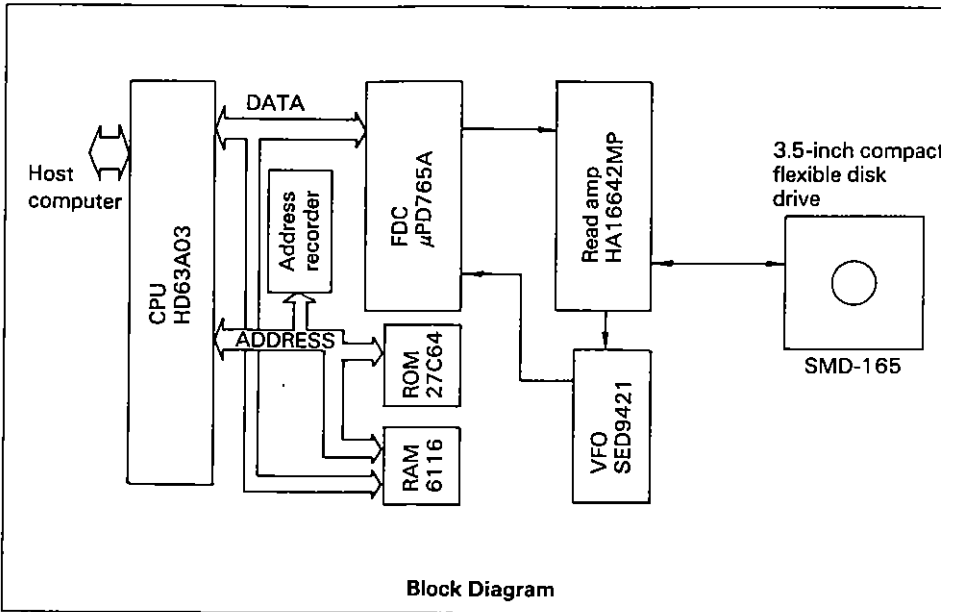

CPU: The CPU controls the entire unit.

ROM: The ROM has a memory capacity of 8 k bytes, and stores the program that activate the CPU.

RAM: The RAM has a memory capacity of 2 k bytes, and is used as the data buffer, the work area for the CPU, etc.

FDC: The floppy disk controller controls the micro-floppy disk drive according to instructions from the CPU.

READ AMP: The read amp amplifies the weak AC signals from the compact floppy disk, shapes their waveforms, and outputs digital output pulses.

VFO Circuit: This is a highly reliable circuit that efficiently separates the clock and data signals from floppy disks.

Compact Floppy Disk Drive: This is a highly dependable, low-power consuming-type, 3.5-inch compact floppy disk drive that reads and writes on micro-floppy disks.

5.2 Interface

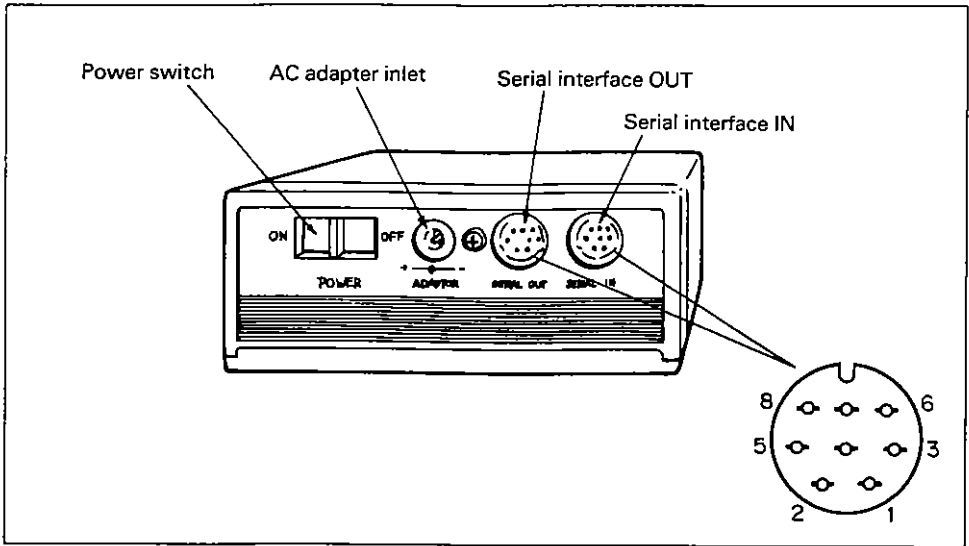

Serial interface IN

Use: This is used for input and output of signals to and from the host computer.

Pin No.	Signal Name	Sending Side	Function
1	SG1	—	Signal ground
2	$\overline{\text{TXD1}}$	PF-10	Send data
3	$\overline{\text{RXD1}}$	Host computer	Receive data

Serial interface OUT

Use: This is used for the floppy disk drive extension.

Pin No.	Signal Name	Sending Side	Function
1	SG1	—	Signal ground
2	$\overline{\text{TXD2}}$	System	Same as $\overline{\text{RXD1}}$
3	$\overline{\text{RXD2}}$	Another terminal	Output as $\overline{\text{TXD1}}$

Chapter 6. SPECIFICATIONS

- (1) Memory Capacity:
 - Memory capacity per drive: 360 k bytes
 - Number of tracks per drive: 80 tracks (40 tracks x 2 sides)
 - Number of sectors per track: 9 sectors/track
 - Memory capacity per sector: 512 bytes/sector
- (2) Memory Density: 8650 BPI (MFM system)
- (3) Transmission Rate: 38.4 k bits/sec (High speed serial)
- (4) Track Density: 67.5 TPI
- (5) Average Rotation Wait Time: 100 msec.
- (7) Access Time:
 - Between tracks: 6 msec.
 - Ave. shifting between tracks: 97 msec.
 - Settling time: 15 msec.
- (8) Head Positioning System: Stepping motor
- (9) Main Shaft Motor: Direct drive system
 - Start-up time: 1.0 sec.
 - Number of revolutions: 300 r.p.m.
- (10) Power Supply:
 - Battery: Ni-Cd battery pack, or dry batteries (LR14, SUM-2 x 4)
 - Ni-Cd battery discharge life: 90 min. continuously after the battery is fully charged. (Operating: one R/W access/2 min. Temperatures: 20°C)
- (11) External Dimensions:
 - Width: 120 mm
 - Depth: 213 mm
 - Height: 59.5 mm
- (12) Weight: 1500g
- (13) Environmental Conditions:
 - Temperatures:
 - When operating: 5°C to 35°C
 - When not operating: -20°C to 60°C
 - Humidity:
 - When operating: 20% to 80% (No condensation)
 - When not operating: 10% to 80% (No condensation)
 - Allowable vibrations:
 - When operating: 0.25G 55 Hz
 - When not operating: 1G 55 Hz
 - Allowable shocks:
 - When operating: 1G 1 msec. or less
 - When not operating: 2G 1 msec. or less

(4) # 726 cable

Usage : Connection between two units or more

Connector: Round-type miniature Round-type miniature

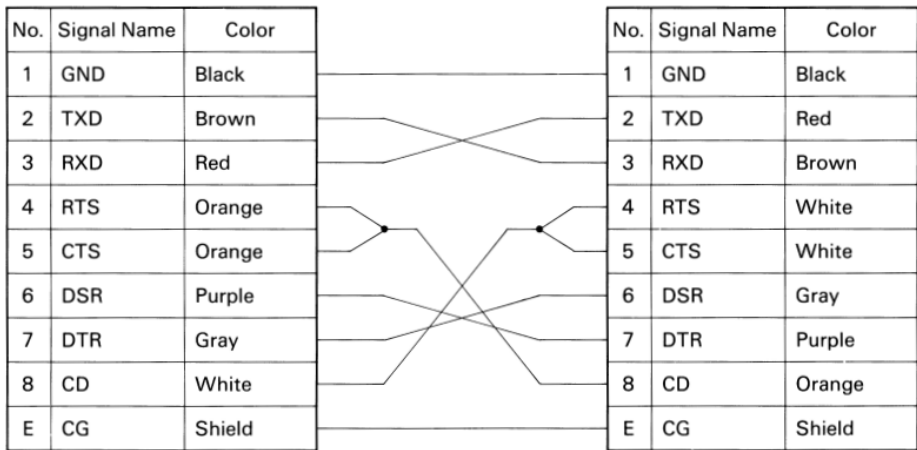
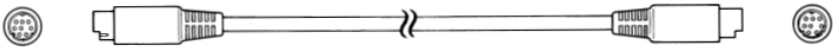

Fig. 1-12

EPSON OVERSEAS MARKETING LOCATIONS

EPSON AMERICA, INC.

3415 Kashiwa Street
Torrance, CA 90505 U.S.A.
Phone: (213) 539-9140
Telex: 182412

EPSON UK LTD.

Dorland House
388 High Road,
Wembley, Middlesex, HA9 6UH, U.K.
Phone: (01) 902-8892
Telex: 8814169

EPSON DEUTSCHLAND GmbH

Am Seestern 24
4000 Düsseldorf 11
F.R. Germany
Phone: (0211) 5952-0
Telex: 8584786

EPSON ELECTRONICS (SINGAPORE) PTE. LTD.

No. 1 Maritime Square, #02-19
World Trade Centre
Singapore 0409
Phone: 2786071/2
Telex: 39536

EPSON ELECTRONICS TRADING LTD.

Room 411, Tsimshatsui Centre,
East Wing, 66, Mody Road
Tsimshatsui Kowloon, Hong Kong
Phone: 3-694343/4
3-7213427
3-7214331/3
Telex: 34714

EPSON ELECTRONICS TRADING LTD. TAIWAN BRANCH

1,8F K.Y. Wealthy Bldg. 206, Nanking
E. Road, Sec. 2, Taipei, Taiwan, R.O.C.
Phone: 536-4339
536-3567
Telex: 24444

EPSON FRANCE S. A.

114, Rue Marius AUFAN
92300 Levallois-perret
France
Phone: (1) 758-77-00
Telex: 614169

EPSON AUSTRALIA PTY. LTD.

Unit 3, Rodborough Road
Frenchs Forest, NSW 2086
Australia
Phone: (02) 452-5222
Telex: (71) 75052
